

# Assembly Instructions for 408116 Steel Drying Rack

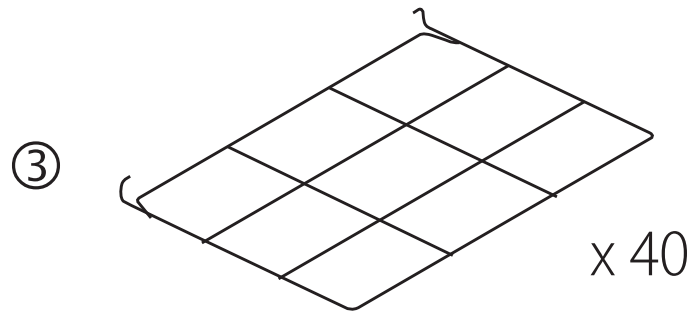

A

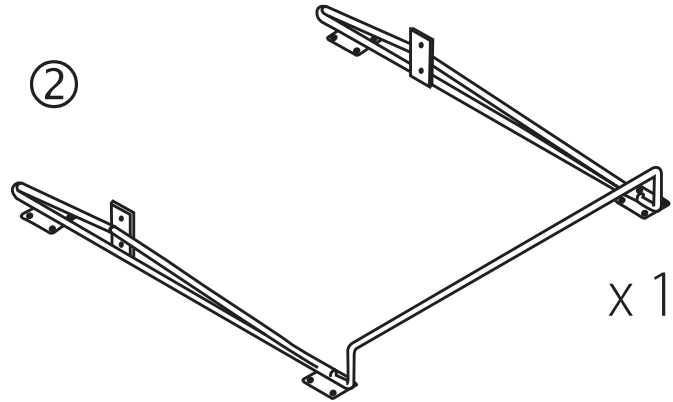
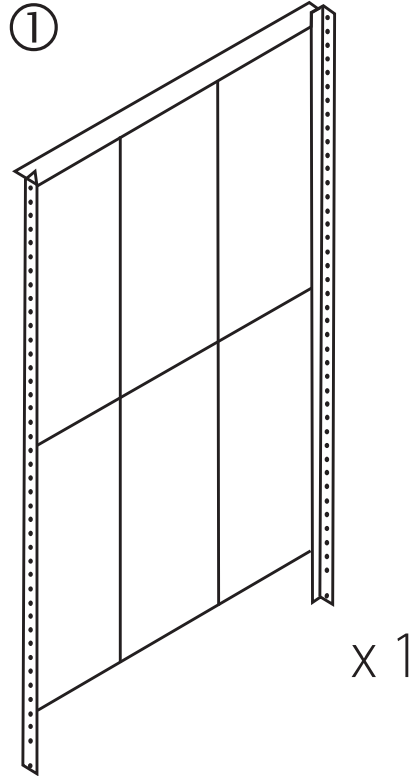
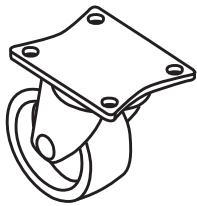

x 4

B

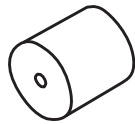

x 80

C

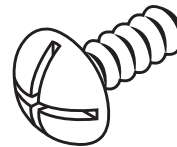

x 20

D



x 40

E



x 20

F



Lock Nuts require extra force to screw in place.

x 20

G

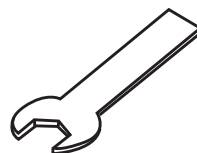

x 1

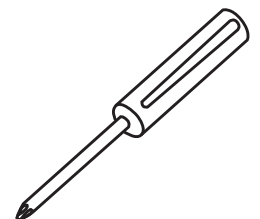

Screwdriver needed (not included).

# Assembly Instructions for 408116 Steel Drying Rack



STEP 1

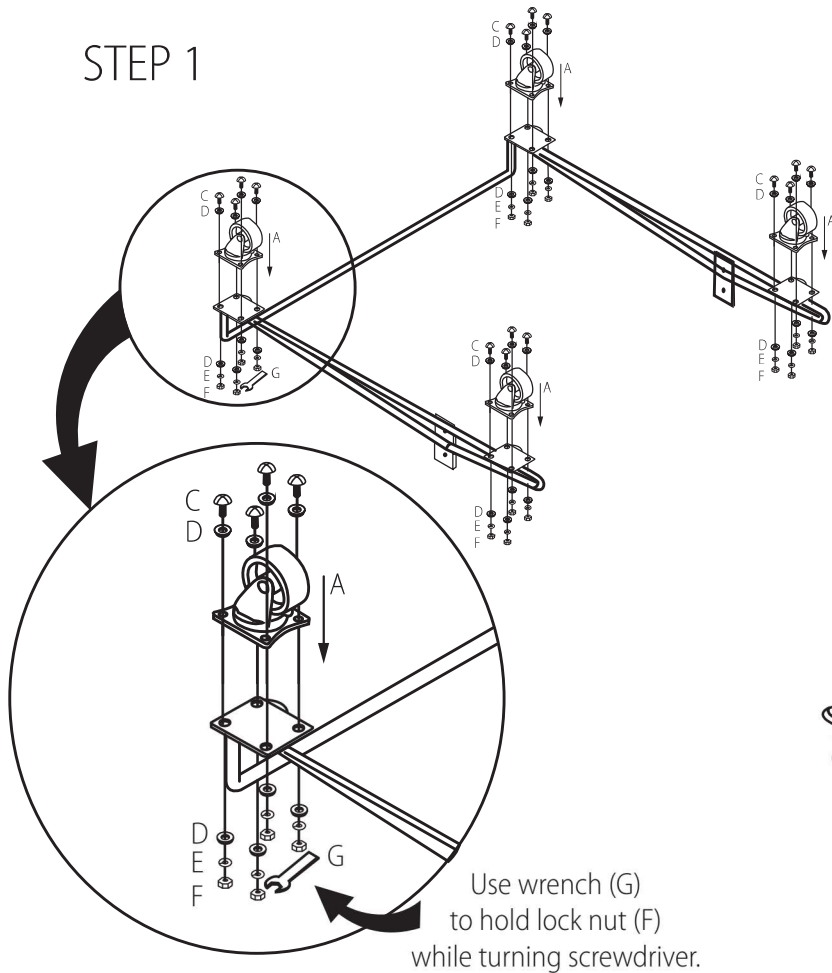

Use wrench (G) to hold lock nut (F) while turning screwdriver.

STEP 2

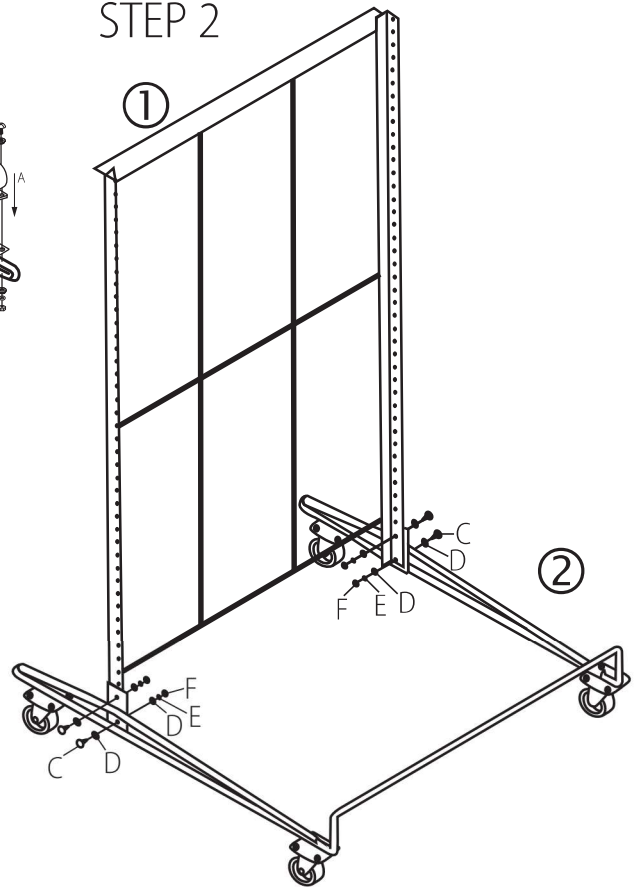

STEP 3

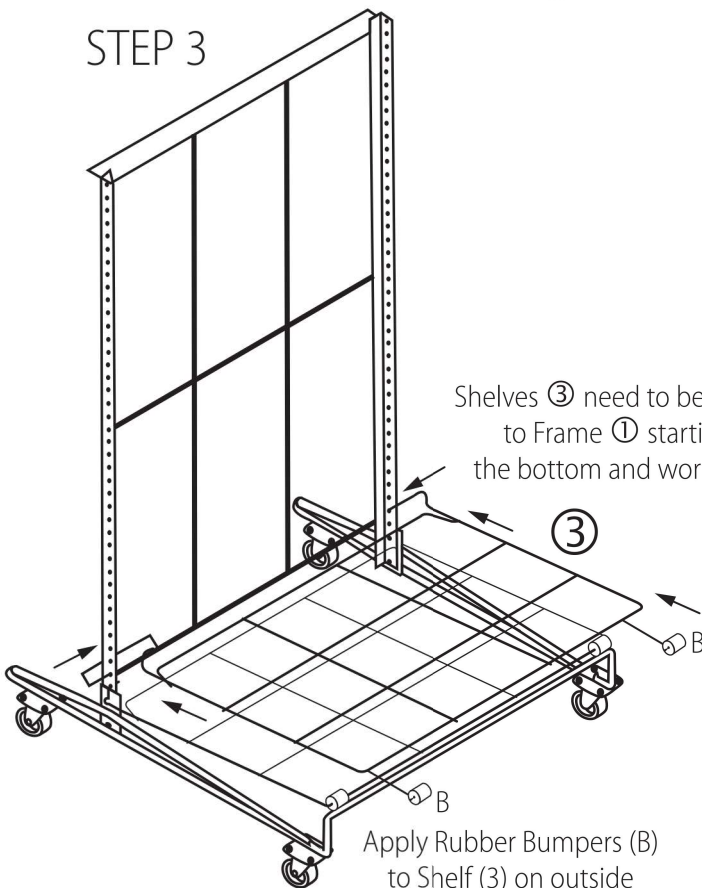

Shelves ③ need to be attached to Frame ① starting at the bottom and working up.

Apply Rubber Bumpers (B) to Shelf (3) on outside edges (as shown).

STEP 4

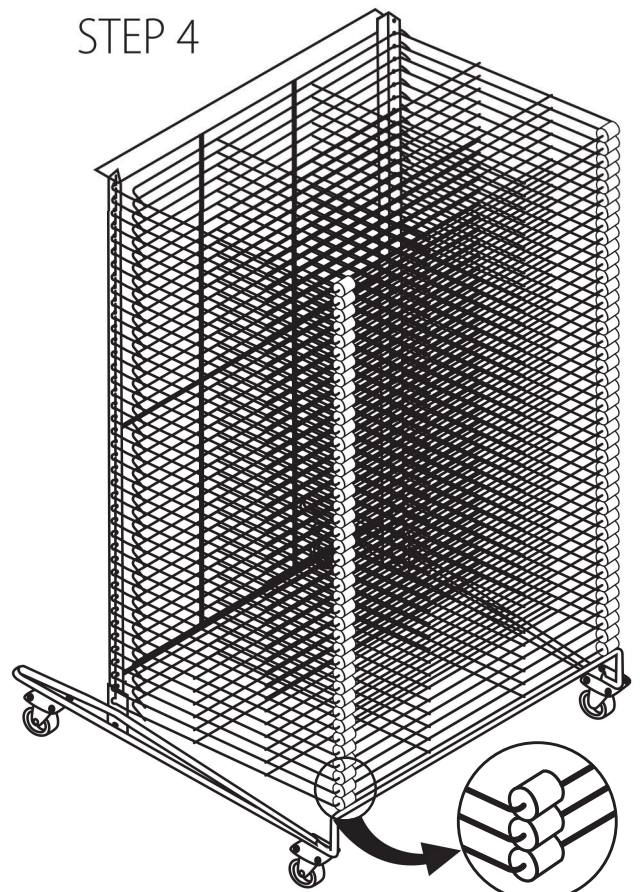

Bumpers need to be aligned so they are supporting each rack.