



Heavy-Duty Steel Drying Rack

40 Shelves = Item# 2125109

50 Shelves = Item# 2125108

Parts Included (40 Shelves/50 Shelves):

#2125109

#2125108

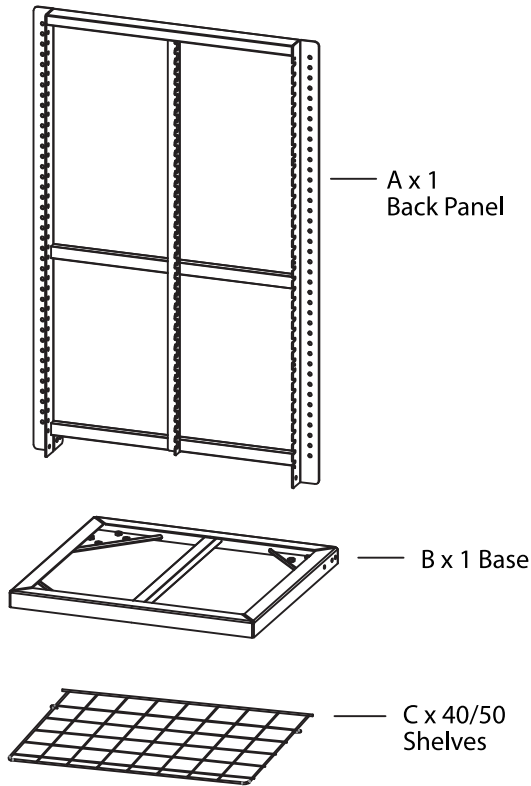

D x 1 Side Bar



E x 5/6 Socket Head Cap Screws

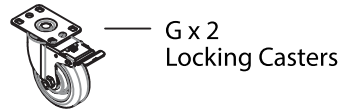
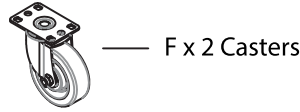

H x 22 Bolts (Three-in-One)

I x 80/100 Eyebolts

J x 80/100 Hex Nuts

K x 80/100 Springs

L x 80/100 Bumpers

Tools Included:

Wrench

Allen Wrench

Spring Puller

Assembly Instructions: allow 2-3 hours for assembly

1

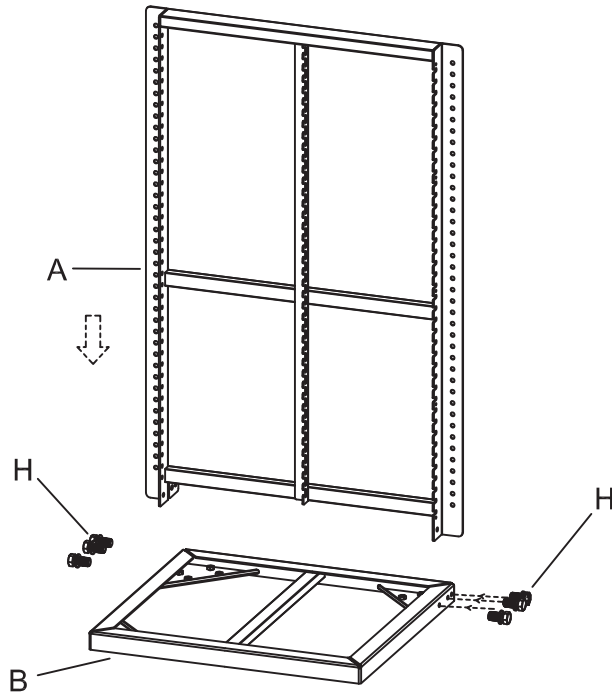

Attach Back Panel (A) to Base (B) using Bolts (H).

2

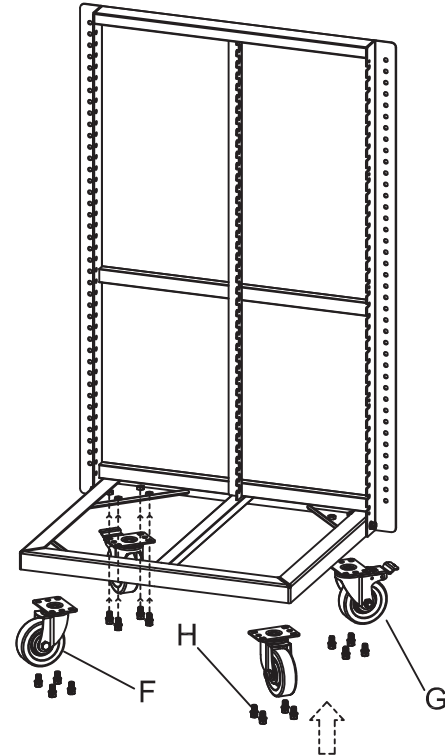

Attach Casters (F & G) to bottom of Base (B) using Bolts (H).

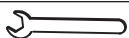

To reduce assembly time during Step 1 & 2, use 1/2" socket wrench (not included) to tighten Bolts.



Heavy-Duty Steel Drying Rack

40 Shelves = Item# 2125109

50 Shelves = Item# 2125108

Assembly Instructions continued:

3

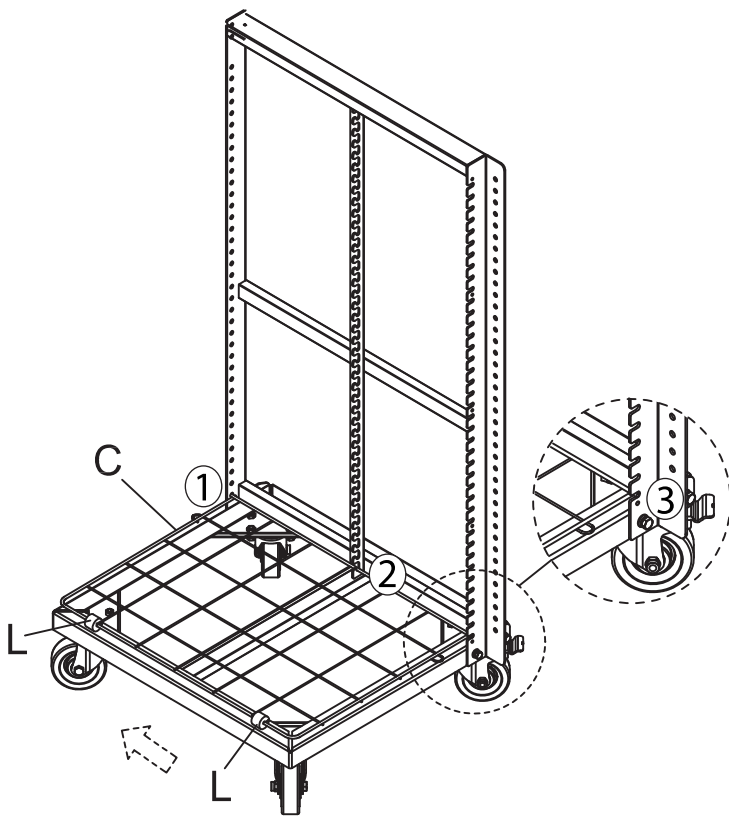

- ① Insert back, left corner of shelf into bottom hole on the back panel, align with corresponding center notch ② and slot on right side of back panel. ③ Attach Bumpers (L) to rounded side of shelf. (Bumpers can be attached to shelves before adding to racks) Continue adding all shelves, working from bottom to top.

4

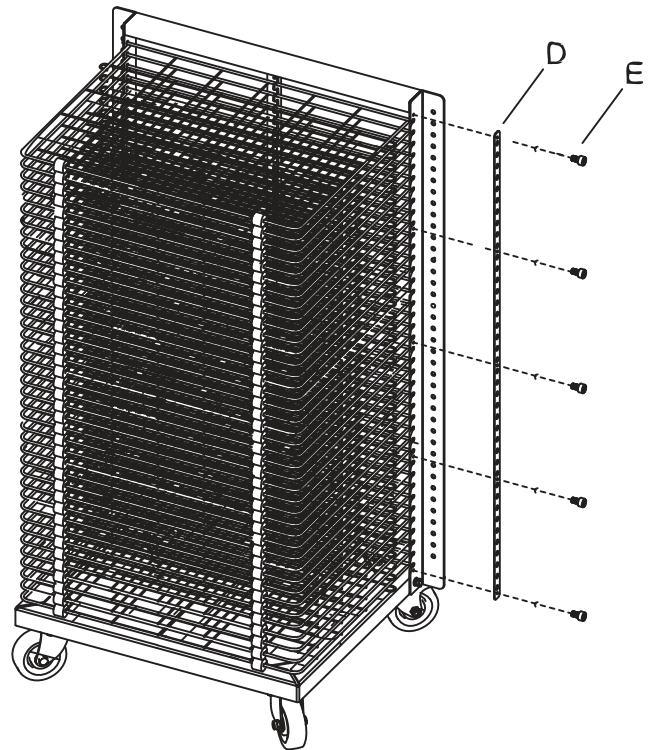

Secure shelves by attaching Side Bar (D) and tightening Socket Head Cap Screws (E) with Allen Wrench. 

Align Bumpers to allow for maximum space between shelves.

5

Unscrew Eye Bolt (I) from Hex Nut (J).

Starting at bottom of rack, insert Eye Bolt through hole in back panel with eyelet facing towards the front. ①

Screw on Hex Nut leaving 1/4"-1/2" of Eye Bolt showing. ② Hook Spring (K) to Eye Bolt. ③

Use Spring Puller  to hook Spring into loop on shelf. Repeat on each side, working from bottom to top. ④

Use Wrench  to adjust tension as needed for shelf to maintain upright position.

